

TOUCH *basic DN*

Document Rev0

Datasheet

LOGIC
office

Cable Handswitch
for installation
below the desktop



Contents

1	Features.....	3
2	Type and dimensions.....	3
3	Technical Data.....	3
3.1	Pin assignment.....	4
4	Compatibility.....	4
5	Order Code.....	4
6	End of life disposal.....	5
7	Manufacturer.....	5

1 Features

- Simple handswitch to move the desktop position up and down
- Big and comfortable to use buttons
- Compatible to all LOGICDATA motor controls
- Easy and fast underside mounting

2 Type and dimensions

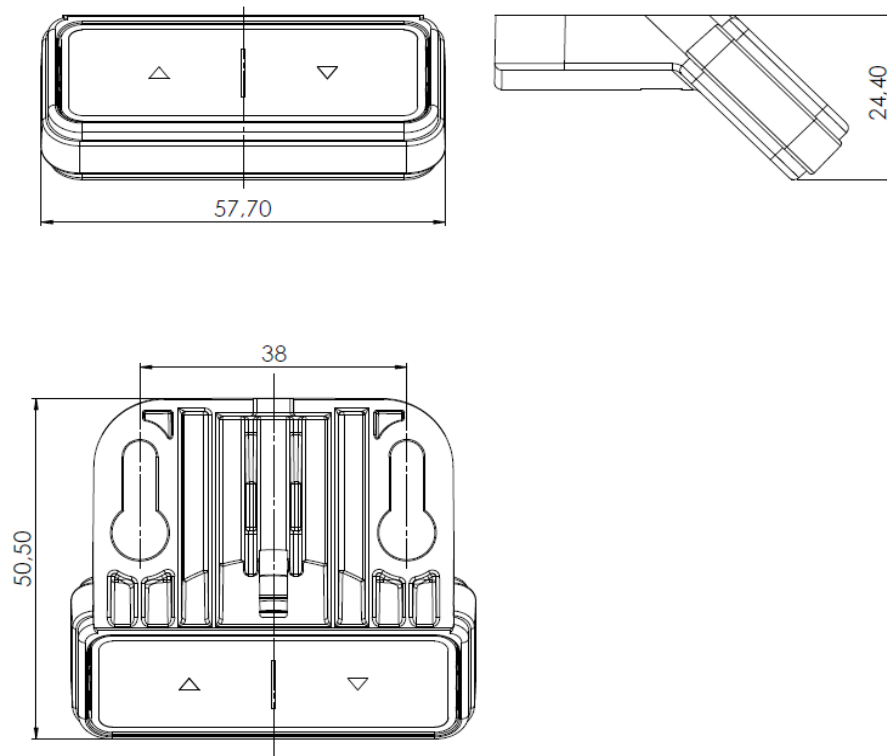

Figure 1: Dimensions in mm; Tolerances according to DIN ISO 2768-1 c

3 Technical Data

General

Supply voltage	5VDC \pm 10%
Current consumption (average)	0mA
Rated switching current	50mA
Life cycle (Switching cycles)	10.000
Ambient temperature	0-30°C
Relative humidity (for operation)	5-85% (non condensing)
Storage and transport temperature	-40-60°C
Relative humidity (for storage)	5-90% (non condensing)
Cable length (including loop)	1800 mm \pm 50mm
Dimensions (L x B x H) [mm]	50,5 x 57,7 x 24,4
Tolerances according to DIN ISO 2768-1 c	
Weight	70 g (cable included)



Caution: The foil of the handswitch might perish or might grow pale due to intensive UV radiation. Therefore avoid direct solar radiation!

3.1 Pin assignment

Handswitch connector

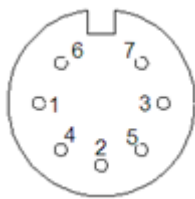

1	n.c.	5	HS2
2	n.c.	6	n.c.
3	HS1	7	+5V
4	n.c.	Shell	n.c.
n.c.	not connected		

Figure 2: Pin assignment of handswitch socket; pin alignment according to DIN 45329



Caution: The TOUCHbasic handswitch is only suitable for **LOGICDATA** motor controls. To prevent damage of the unit, take care not to interchange handswitch and motor sockets.

Pin	Description
+5V	Power supply line
HS1, HS2	Parallel handswitch lines

4 Compatibility

The TOUCHbasic handswitch is compatible to following LOGICDATA motor controls:

- SMART
- COMPACT
- COMPACT-e
- COMPACT-e+

5 Order Code

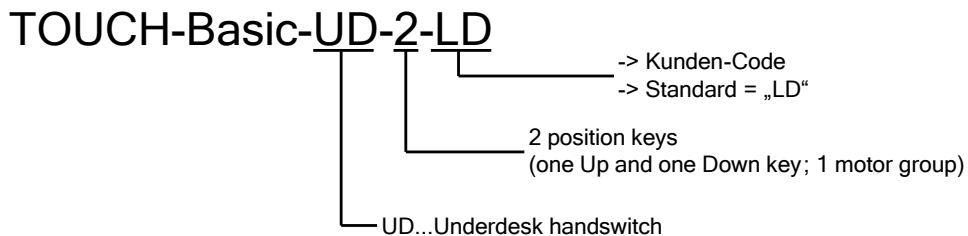

Figure 3: Order code



Note: For further information about other models of TOUCHbasic-UD please contact LOGICDATA

6 End of life disposal

When you no longer require the TOUCHbasic cable handswitch, please note the following for disposal:



Note: the TOUCHbasic cable handswitch is electrical or electronic equipment according to directive 2002/96/EC and therefore marked with the symbol depicted on the left.



Note: ensure eco-friendly disposal of all the handswitch components (separate the plastic and electronic parts for collection).

Also ensure eco-friendly disposal of all the other components (drives, cables, etc.).



Note: this product is RoHS compliant according to directive 2002/95/EC!



Note: this product is REACH compliant according to directive 2006/121/EC (Edict 1907/2006)

7 Manufacturer

LOGICDATA

Electronic & Software Entwicklungs GmbH

Wirtschaftspark 18

A-8530 Deutschlandsberg - Austria

Tel.: +43 (0)3462 5198 0

Fax: +43 (0)3462 5198 530

Email: office@logicdata.at

URL: www.logicdata.at