



# TOUCHinlay

**Infinite Flexibility.**

## DESCRIPTION

The TOUCHinlay Handset implements touch technology into a low profile digital display Handset. With its inset design and large, comfortable buttons and displays, it provides exceptional control of movement. Its TOUCH panel is customizable and the height display is available in inches or centimeters. It gives optimal movement control and a programmable memory function for up to 2 positions.

## FEATURES

- Customizable Handset
- Individual button and function layout
- 2 memory positions
- Up to 2 motor groups
- 4-digit display for inch or cm
- TOUCH & CLICK function
- Key lock



### Contact Headquarters

LOGICDATA Electronic & Software Entwicklungs GmbH  
Wirtschaftspark 18, 8530 Deutschlandsberg, [office.at@logicdata.net](mailto:office.at@logicdata.net)

### North America

LOGICDATA North America Inc., 1525 Gezon Parkway SW,  
Suite C Grand Rapids, MI 49509, USA, [office.na@logicdata.net](mailto:office.na@logicdata.net)

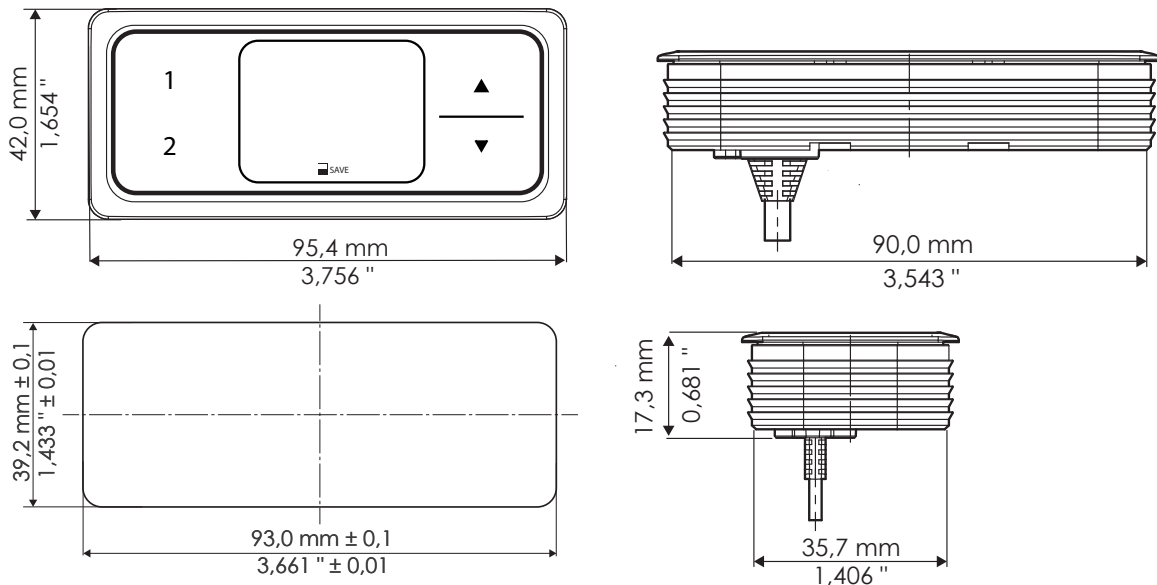

(A) Cut-out

## TECHNICAL DATA

<b>Supply voltage</b>	5 V DC $\pm$ 200 mV
<b>Current Consumption (average)</b>	60 mA
<b>Current Consumption (standby)</b>	<1.3 mA
<b>Service life</b>	10 000 cycles
<b>Cable length</b>	2 000 mm / 78.740" ( $\pm$ 40 mm / 1.575")
<b>Dimensions (l x w x h)</b>	42.0 x 95.4 x 17.3 mm / 1.654" x 3.756" x 0.681"
<b>Dimensions (milled cut-out)</b>	39.2 x 93.0 mm / 1.433" x 3.661" ( $\pm$ 0.1 mm / 0.01")
<b>Weight (including cable)</b>	86 g
<b>Ambient conditions during operation</b>	+5 °C to +40 °C at max. 68% relative air humidity (non-condensing), up to an altitude of 2,000 m.
<b>Ambient conditions during transport and storage</b>	-25 °C to +40 °C at max. 68% relative air humidity (non-condensing). +40 °C to 60 °C at max. 32% relative air humidity (non-condensing). Temperatures of more than 40 °C for periods not exceeding 10h. Product must be acclimatised to acceptable operating conditions before assembly. Contact LOGICDATA for exact specifications.
<b>Compatibility</b>	All LOGICDATA Control Boxes, except integrated Control Units in the LOGICdrive and DYNAMIC MOTION families.
<b>Degree of protection (IEC 60529)</b>	IP 20
<b>Standards and regulations</b>	EMC directive 2014/30/EU RoHS directive 2011/65/EU
<b>Order Code</b>	<b>TOUCH-IL-MDF-2M2-LD (without Key Lock)</b> <b>TOUCH-IL-MDF-2M2-KL (with Key Lock)</b>