

DOCUMENT VERSION 0 | JANUARY 2023

DCCinline D

Manual





DCDinline D Operating Manual

Document Version 0 / January 2023

This document was originally published in English.

LOGICDATA Electronic & Software Entwicklungs GmbH

Wirtschaftspark 18
8530 Deutschlandsberg
Austria

Phone: +43 (0) 3462 51 98 0
Fax: +43 (0) 3462 51 98 1030
Internet: www.logicdata.net
Email: office.at@logicdata.net



CONTENT

1	Introduction	5
1.1	Copyright	5
1.2	Royalty-Free Use of Images and Text	5
1.3	Trademarks	5
1.4	Symbols and Signal Words Used	6
2	Safety	6
2.1	General Safety Regulations and Obligations	6
2.2	Qualified Persons	7
2.3	Liability	7
3	Product	8
3.1	Description	8
3.2	Intended Use	9
4	Delivery Scope	9
5	Unpacking	10
6	Assembly	10
6.1	General Assembly	10
6.1.1	Actuator Dimensions	11
6.1.2	Installation Options	11
6.1.3	Installation Tolerances	12
6.1.4	Default Settings	13
6.2	Assembly “Thick End Up” Variant	13
6.2.1	Attaching the Middle Tube	13
6.3	Assembly “Thick End Down” Variant	15
6.4	Motor Side Interface	16
6.5	Flange Side Interface	17
7	Software-Dependent Functions	17
8	Intelligent System Protection (ISP)	18
9	Disassembly	18



10	Maintenance	19
11	Troubleshooting	19
12	Additional Information	21
12.1	Technical Specifications	21
12.2	Optional Products	21
12.3	Disposal	21



1 INTRODUCTION

The product documentation consists of this manual and a datasheet.

This document is intended to enable the assembly personnel to work safely with the DCDinline D actuator. The assembly personnel must therefore always have the complete documentation available. The document must be complete and in a perfectly legible condition. Follow the instructions in this document to avoid hazards and to prevent damage to the DCDinline D.

The information in this document has been compiled with great care. We strive to ensure the accuracy and completeness of the content by revising it and updating it regularly, however, no guarantee can be given for its accuracy and completeness.

1.1 COPYRIGHT

© January 2023 by LOGICDATA Electronic und Software Entwicklungs GmbH. All rights reserved, except for those listed in Chapter 1.2 Royalty-free use of images and text on page 5.

1.2 ROYALTY-FREE USE OF IMAGES AND TEXT

After purchase and full payment of the product, all text and images in Chapter 2 “Safety”, may be used free of charge by the customer. They should be used to prepare end user documentation for Height-Adjustable Table Systems. The license does not include logos, designs, and page layout elements belonging to LOGICDATA. The transfer of this license to third parties without permission from LOGICDATA is excluded. Full ownership and copyright of the text and graphics remain with LOGICDATA. Texts and graphics are offered in their current state without warranty or promise of any kind.

1.3 TRADEMARKS

Documentation may include the representation of registered trademarks of goods or services, as well as information about copyright or other proprietary expertise of LOGICDATA or third parties. In all cases, all rights remain exclusively with the respective copyright holder. LOGICDATA® is a registered trademark of LOGICDATA Electronic & Software GmbH in the USA, the European Union, and other countries.



1.4 SYMBOLS AND SIGNAL WORDS USED

Safety Notices contain both symbols and signal words. The signal word indicates the severity of the hazard.

 **CAUTION** **Danger of material damage and possible additional low risk of injury.**
 A safety notice with the signal word „Caution“ indicates a hazardous situation which, if not avoided, could result in minor or moderate injury.

NOTICE The label NOTICE indicates a situation that will not lead to personal injury, but could lead to damage to the product or the environment.

 **NOTICE** Damage due to electrostatic discharge (ESD)

2 SAFETY

2.1 GENERAL SAFETY REGULATIONS AND OBLIGATIONS

In general, the following safety regulations and obligations apply when handling the product:

- The DCDinline -DR actuator may only be operated in a clean and perfect condition.
- Do not remove, change, bridge or bypass any protection, safety or monitoring equipment.
- Do not convert or modify the DCDinline D actuator without written approval from LOGICDATA.
- In the event of malfunction or damage, the DCDinline D actuator must be replaced immediately.
- Do not attempt to repair the acuator yourself.
- Hardware replacement is only allowed in a de-energized state.
- For the operation of the system, the national worker protection conditions and the national safety and accident prevention regulations apply.



2.2 QUALIFIED PERSONS

The DCDinline D may only be installed and commissioned by qualified persons who are authorized for installation planning, installation, commissioning or maintenance/servicing and who have read and understood the DCDinline D documentation. Qualified persons have the necessary expertise to test, assess and manage electrical and mechatronic products and systems in accordance with the generally accepted standards and guidelines of electrical engineering and furniture manufacturing through their education, work experience and recent professional activity. They know and adhere to the basic regulations on occupational safety and accident prevention and the basic norms and specialist standards applicable to the specific application.

2.3 LIABILITY

The products comply with the applicable state of the art health and safety regulations. Nevertheless, dangers can result from incorrect operation or misuse.

LOGICDATA is not liable for damages caused by:

- Improper use of the products
- Disregard of the documentation
- Unauthorized changes to the products
- Improper work on and with the DCDinline D
- Operating a damaged product
- Wear parts
- Improperly performed repairs
- Unauthorized, improper change of operating parameters
- Disasters, external influence and force majeure

Responsible for the LOGICDATA products in the specific application and compliance with the relevant directives, standards and laws is the manufacturer of the height-adjustable tables in which the LOGICDATA products are installed. LOGICDATA shall not be held liable for any damage that is directly or indirectly attributable to the delivery, performance or use of this document. Each reseller must take into account the relevant safety standards and guidelines for his product in which the DCDinline D is installed.



3 PRODUCT

3.1 DESCRIPTION

The DCDinline D is an actuator for electrically height-adjustable tables. It is installed by the customer in a column for electrically height-adjustable tables. It is controlled by a control unit from LOGICDATA, to which different hand switches can be connected. Several drives can be operated synchronously on one control unit.

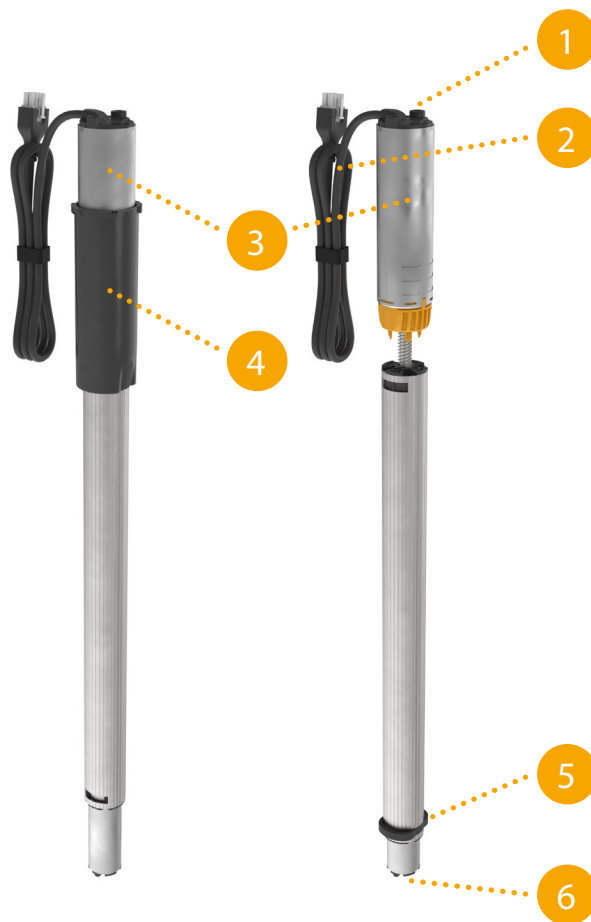

Fig. 1: DCDinline D

1	Attachment point on motor end (screws and rubber discs provided)
2	Connection cable
3	Motor
4	Attachment point middle tube with installation variant - thick end up
5	Attachment point middle tube with installation variant - thick end down
6	Flange attachment point



3.2 INTENDED USE

The DCDinline D actuator may only be installed in telescopic tubes to adjust electrically height-adjustable tables and used for this purpose exclusively. The intended use is to adjust the table height electrically. Only control units from LOGICDATA, which are parameterized for the DCDinline D, may be used for this purpose. The actuators must be assembled, commissioned and functionally checked by qualified personnel. Any other use that does not conform to the intended use will result in the loss of warranty and warranty claims.

The basic function is the upward and downward movement (of a table top). This function can be executed with suitable hand switches from LOGICDATA.

NOTICE Permissible drive loads and speeds always refer to the product DCDinline D and not to the additional load on the table system. The reseller must take additional loads such as e.g. friction forces, the deadweight of the table components and torque loads into consideration. The newly determined permissible load must be specified in the parent documentation of the final product.

4 DELIVERY SCOPE

The standard scope of delivery for the DCDinline D actuator consists of the following components:

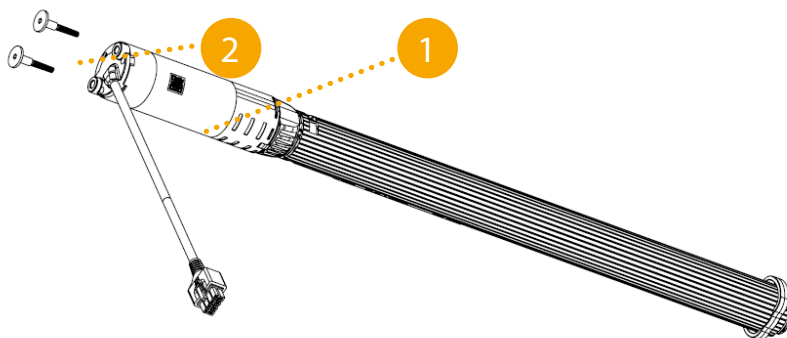

Fig. 2: Delivery scope

Standard delivery scope

1	DCDinline D actuator
2	Two mounting screws incl. rubber disks (LOG-PRT-SD-MOUNTINGSCREW)



5 UNPACKING

The DCDinline D actuator is packaged in a carton.

**NOTICE**

Ensure proper ESD handling during unpacking. Errors that can be attributed to electrostatic discharge will void warranty claims

To unpack, proceed as follows:

1. Remove the packaging material from the drive components.
2. Check the contents of the package for completeness and damage.
3. Provide the operating manual to the operating personnel.
4. Dispose of the packaging material.

NOTICE

Dispose of the packaging material in an environmentally friendly manner (separate the plastic parts and the cardboard by type).

6 ASSEMBLY

6.1 GENERAL ASSEMBLY

NOTICE

Before assembly and operation, the DCDinline D must be acclimatised to the ambient conditions.

**NOTICE**

Ensure proper ESD handling throughout the installation. Errors that can be attributed to electrostatic discharge will void warranty claims.



6.1.1 ACTUATOR DIMENSIONS

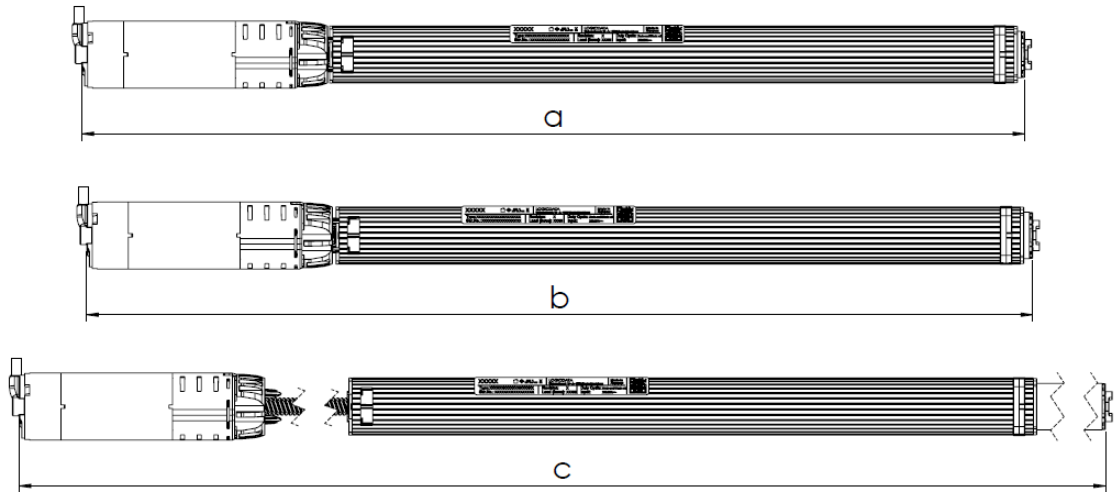

Fig. 3: a: retracted length, b installation length, c extended length

6.1.2 INSTALLATION OPTIONS

The DCDinline D is designed for synchronous movement of the middle tube.



Fig. 4: Synchronous movement of the middle tube results in the distances x being the same at all times independently from the current height (middle tube removed for easier demonstration).



For this it is necessary to connect the drive with the middle tube of the height-adjustable column. Depending on the type of height-adjustable column design, different installation requirements must be taken into consideration. In this document, the installation variants are characterized as follows, depending on the types of height-adjustable columns:

- “Thick end up”: In this variant, the tube with the largest diameter is at the top (table top).
- “Thick end down”: In this variant, the tube with the largest diameter is at the bottom (floor).

The DCDinline D actuator can be used for both variants.

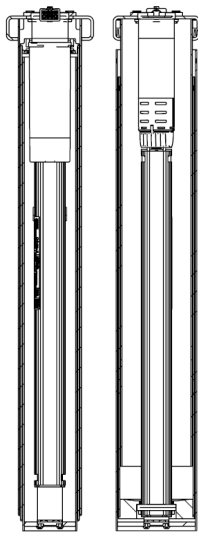

Fig. 5: “Thick end up” (left) and “Thick end down” (right) in retracted position

NOTICE Regardless of the installation variant, the inner diameter of the inner tube must be selected so that a surrounding air gap of min 3 mm between the inner wall of the tube and the DCDinline D is guaranteed.

NOTICE As shown in Figure 5, height-adjustable columns must be designed so that the motor end of the DCDinline D is always up

6.1.3 INSTALLATION TOLERANCES

NOTICE In order to ensure proper functioning, height-adjustable columns must comply with the tolerances specified by LOGICDATA. Otherwise, the warranty claims are void. These tolerances are published by LOGICDATA on request.



6.1.4 DEFAULT SETTINGS

NOTICE Failure to follow the instructions below may result in damage!

NOTICE LOGICDATA recommends measuring the dimensions of the DCDinline D before assembly with a gauge or other suitable measuring equipment.

NOTICE In order to utilize the complete stroke of the drive, a corresponding design of the height-adjustable column is necessary. It is important that the drive reaches the final position before the tube.

NOTICE Deviating flange settings may only be implemented in consultation with LOGICDATA.

6.2 ASSEMBLY “THICK END UP” VARIANT

This chapter explains the installation with installation option “thick end up” in more detail. If you are using the installation of the “thick end down” column, skip this chapter and continue with 6.3.

6.2.1 ATTACHING THE MIDDLE TUBE

The tube adapter is intended to connect the drive with the middle tube of the height-adjustable column via a special counterpiece (see Figure 6: Symbolic image of the counterpiece for the tube adapter).

NOTICE The design specifications for the customer-provided counterpiece are available from LOGICDATA only on request. These includes dimensions and tolerances as well as notes on material selection and assembly.

⚠ CAUTION **Danger due to insecure connection**
To ensure a secure connection, the counterpiece must be designed exactly to the specifications of LOGICDATA. Otherwise, the warranty claims are void.

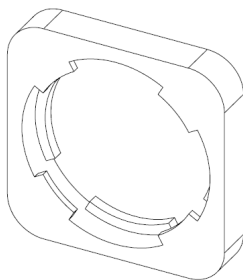

Fig. 6: Symbolic image of the counterpiece for the tube adapter



Recommended assembly procedure:

NOTICE The assembly procedure shown is based on a height-adjustable column design in which the top plate can be removed (i.e., it is not permanently connected to the thick end). For instructions on mounting with other height-adjustable column constructions, please contact LOGICDATA.

NOTICE We recommend measuring the friction of the tube pairs before installing the drive! The combination of control unit and drive is not a suitable means for measuring the friction!

Proceed with the following steps for the assembly with the installation variant “thick end up”:

1. Assemble the counterpiece for the tube adapter (see Figure 6: Symbolic image of the counterpiece for the tube adapter) in the middle tube.
2. Insert the three tubes into each other.

NOTICE LOGICDATA recommends measuring the gliding properties of the height-adjustable column without the installed drive after this step.

NOTICE The maximum force on the tube adapter counterpart must not exceed 150N! This is due to a difference in frictional forces between the tube pairs.

3. Mount the drive in the preassembled height-adjustable column (see Figure 7: Example of actuator installation in a round height-adjustable column by rotating it 1/8 turn clockwise when seen from top).
4. Then make the attachment on the motor end and flange end according to Chapter 6.4 and Chapter 6.5.

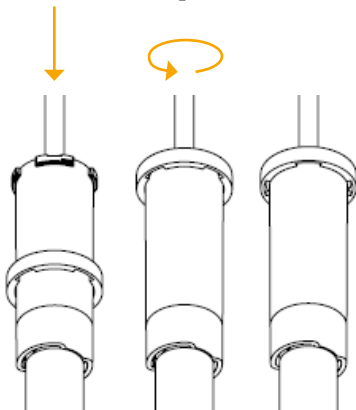

Fig. 7: Example of actuator installation in a round height-adjustable column



6.3 ASSEMBLY “THICK END DOWN” VARIANT

The middle tube adapter is produced by the customer and is fixed in the middle tube. It is connected to the drive in the installation variant “thick end down”.

NOTICE The design specifications for the middle tube adapter are available from LOGICDATA only on request. These includes dimensions and tolerances as well as notes on material selection and assembly.

⚠ CAUTION **Danger due to insecure connection**
To ensure a secure connection, the middle tube adapter must be designed exactly to the specifications of LOGICDATA. Otherwise, the warranty claims are void.

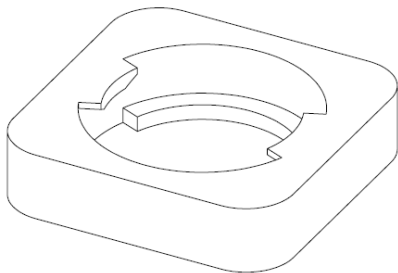

Fig. 8: Symbolic image of the middle tube adapter

Recommended assembly procedure:

NOTICE The assembly procedure shown is based on a height-adjustable column design in which the top plate can be removed (i.e., it is not permanently connected to the inner tube). For instructions on mounting with other height-adjustable column constructions, please contact LOGICDATA.

NOTICE We recommend measuring the friction of the tube pairs before installing the drive! The combination of control unit and drive is not a suitable means for measuring the friction!

Proceed with the following steps for the assembly with the installation variant “thick end down”:

1. Assemble the middle tube adapter (see Figure 8: Symbolic image of the middle tube adapter) in the middle tube.
2. Insert the three tubes into each other.

NOTICE For suitable production aids, joining forces and joining speeds or detailed information on the assembly process, please contact LOGICDATA. Failure to perform the joining process properly may result in damage to the DCDinline D.

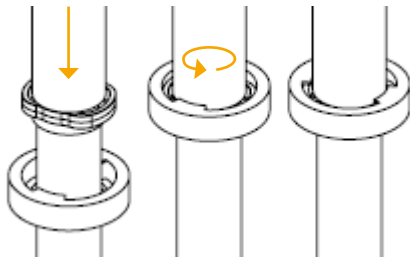

Fig. 9: Assembling the middle tube

3. Insert the actuator into the column. With the middle tube attachment point fitted in the middle tube adapter, turn it 90 degrees in any direction.
4. Attach at the motor end and flange end according to Chapter 6.4 and Chapter 6.5.

6.4 MOTOR SIDE INTERFACE

NOTICE The design specifications for the top plate are available from LOGICDATA only on request. These includes dimensions and tolerances as well as notes on material selection and assembly.

NOTICE Do not lift the DCDinline D by the cable and make sure that the cable is not damaged during assembly

NOTICE The screws and rubber disks are supplied together with the drive. The mounting screws must be tightened to the recommended tightening torque of 2.5 - 3 Nm.

NOTICE The DCDinline D can only be mounted once with the supplied screws, otherwise correct tightening of the mounting screws can not be guaranteed.

NOTICE Mounting without rubber disks is not permitted.

⚠ CAUTION **Danger due to insecure connection**
To ensure a secure connection, the top plate must be designed exactly to the specifications of LOGICDATA. Otherwise, the warranty claims are void.



6.5 FLANGE SIDE INTERFACE

The figure below provides an overview of the components required to assemble the drive on the flange end.

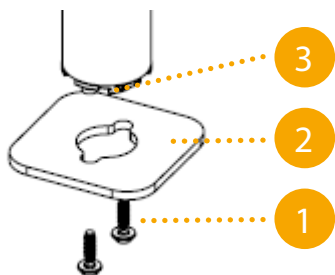

Fig. 10: Overview of the flange end

1	Mounting screw (adapted by the customer to bottom plate)
2	Bottom plate (developed by the customer, design specifications of LOGICDATA)
3	Flange adjustment point

NOTICE The design specifications for the bottom plate are available from LOGICDATA only on request. These includes dimensions and tolerances as well as notes on material selection and assembly.

⚠ CAUTION **Danger due to insecure connection**
To ensure a secure connection, the top plate must be designed exactly to the specifications of LOGICDATA. Otherwise, the warranty claims are void.

7 SOFTWARE-DEPENDENT FUNCTIONS

NOTICE The description of the software-dependent functions, for example: manual reset, plug detection or auto detect number of drives can be found in the corresponding manual of the controlbox.



8 INTELLIGENT SYSTEM PROTECTION (ISP)

ISP (Intelligent System Protection) was developed by LOGICDATA to reduce the risk of pinching when a moving table hits an obstacle. A load change can be detected, either by sensors in the actuators, or other sensors. The table will stop instantly and move in the opposite direction for a few millimeters.

There are two types of ISP:

Software ISP

Software ISP uses known system variables that are measured or calculated by each controlbox. Additional sensors are not necessary, this function is available with all LOGICDATA controlboxes and all drives.

Sensor ISP

Optionally, the drive can be equipped with sensor ISP, which increases the sensitivity of the collision detection.

NOTICE The description of the activation and deactivation of ISP sensors can be found in the corresponding manual of the controlbox.

NOTICE The ISP sensitivity and the ISP switch-off value depend on the complete system (mechanical and electronic components). To determine the ISP suitability of a height-adjustable table, please contact LOGICDATA!

NOTICE Within a system, drives with and without ISP sensors cannot be mixed. Each drive must be of the same type.

9 DISASSEMBLY

For disassembly, disconnect the DCDinline D from the power supply and proceed in reverse order to assembly.



10 MAINTENANCE

**NOTICE****Hazards from the use of incorrect accessory parts**

Only use original accessory parts. These may only be installed by expert service personnel. Otherwise your warranty claims will be void.

**NOTICE****Hazard from inappropriate repairs**

Contact your customer service immediately in the event of a malfunction. Only original spare parts are approved for the repair of the drives. These may only be replaced by expert service personnel. Otherwise your warranty claims will be void.

11 TROUBLESHOOTING

For technical problems, please contact our support at:

Phone: +43 (0) 3462 51 98 0
Fax: +43 (0) 3462 51 98 1030
Email: office.at@logicdata.net

Always provide the product name and the revision status according to the type plate with any support request. In case of a defect, replace the DCDinline D as a whole.



Possible malfunctions and their remedy:

PROBLEM	POSSIBLE CAUSE	REMEDY
DCDinline D does not function	Mains cable of the controlbox not connected	Plug in the mains cable of controlbox
	DCDinline D actuator is not connected	Plug the motor cable into the controlbox
	Poor plug connection	Plug in the motor cable, mains cable, and hand switch properly
	Controlbox defective	Contact LOGICDATA
	Hand switch defective	Replace the hand switch
	DCDinline D actuator defective	Replace the DCDinline D actuator
	An error code appears on the display of the hand switch	Check the error code on the hand switch display or the click code of the controlbox, search the complete error code list in the operating instructions of the controlbox
DCDinline D only moves down (retracted position)	Power failure while moving or power cable unplugged while moving	Manual reset *)
	Reset required	Perform a reset
	DCDinline D actuator defective	Replace the DCDinline D actuator

*) If actuators only move down

NOTICE A detailed description of the error codes on hand switches as well as click codes can be found in the corresponding manual of the controlbox.



12 ADDITIONAL INFORMATION

12.1 TECHNICAL SPECIFICATIONS

You can find the technical data of your drive in the corresponding data sheet.

12.2 OPTIONAL PRODUCTS

NOTICE You can find information about available optional products in the current product catalog and at www.logicdata.net

12.3 DISPOSAL



All LOGIClink products are subject to the WEEE Directive 2012/19/EU.

- Dispose of all components separately from household waste. Use designated collection points or disposal companies authorized for this purpose



LOGICDATA
Electronic & Software Entwicklungs GmbH
Wirtschaftspark 18
8530 Deutschlandsberg
Austria

Phone: +43 (0)3462 5198 0
Fax: +43 (0)3462 5198 1030
E-mail: office.at@logicdata.net
Internet: <http://www.logicdata.net>

LOGICDATA North America, Inc.
1525 Gezon Parkway SW, Suite C
Grand Rapids, MI 49512
USA

Phone: +1 (616) 328 8841
E-mail: office.na@logicdata.net



www.logicdata.net